



GHADIR LOULEH PASSARGAD CO.

**MANUFACTURER OF CORRUGATE PE PIPE AND
PE MANHOLE**

www.Ghadirlouleh.com

MANHOLE INSTALLATION GUIDE

INTRUDUCTION

Ghadir Louleh passargad Corporation is one of the largest producers of **Polyethylene manhole** and Corrugate and water PE pipes all over the country.

Polyethylene manholes are applied in industrial and domestic sewage. Regarding the increasing usage of polymeric products in various global industries, this product is an appropriate alternative to concrete or other construction materials.

PE manhole is a new product of Ghadir louleh which is manufactured of finest raw material with best design, compared to similar samples. This product has wide range of application such as oil, gas and petrochemical industry, power plants and urban transmission pipelines.



POLYETHYLENE MANHOLE

Inspection Chambers or PE manhole shall be installed on the line in specific intervals to ensure regular and problem-free operation of infrastructure, rainwater, drainage and sewerage system lines of modern cities. Conventional inspection chambers employed in infrastructure and sewerage systems are being replaced by high-tech inspection chambers made of polyethylene due to lack of resistance to chemicals, heavy and bulky structure, production, handling, application and installation challenges. PE inspection chambers are widely employed in process water, return lines or water lines which require continuous circulation at industrial plants thanks to their superior features



GHADIR LOULEH CO.

00982186038220-
00989121970655

The General advantage of PE Manhole :

- 1. Lower manufacturing and installation costs compared to concrete ones**
- 2. Less running time for PE manholes compared to concrete manholes.**
- 3. Resistant to a large number of chemical -as a unique property of Ghadir louleh manholes- compared to concrete ones.**
- 4. No need to have heavy machineries**
- 5. Durable to chemical environment and humid climate**
- 6. No repairing need. Easy to change size in case of need**
- 7. Easy installation in sewage transmission lines and significant cost reducing in large projects implementation.**





Manhole Sealing

Different parts of manholes need to be sealed and for this matter EPDM gasket to be used. From the other hand all bolts and Gaskets must be hot galvanized.

for more interest : please find the information of raw material to be used in polyethylene manholes in the below schedule.

Property	unit	value
Density	Gr/cm3	0.935-0.939
Melt Index	Gr/10min	3.8-4.5
Flex	Mpa	650
Strength	Mpa	Min 15
Impact Strength	Kj/m2	Min 18

Anti UV Raw Material Based on national standard, **PE Manholes** should be able to have at least one year outdoor durability.

Polyethylene raw material witch made by Iranian refineries have untie additives and no more need to added carbon black.

Ghadir Inspection Chambers are manufactured using Rotational Molding Technology up to DN 1000 and 1200 mm diameter and a height to 1.5 meters up to customer design on base of 14148 standard. The thickness of manhole is 10mm or more and Annular resistance is SN=8 . The body of Manholes are sealed and all parts are connected with EPDM washers. Stairs made by polyethylene as a single unit.

Polyethylene inspection chambers have high chemical resistance. They are particularly preferred at areas with intensive corrosion and sealing requirements. Harsh chemicals which have a corroding effect with other materials in a short time do not impair the structure of PE material.



PARTS OF PE MANHOLES

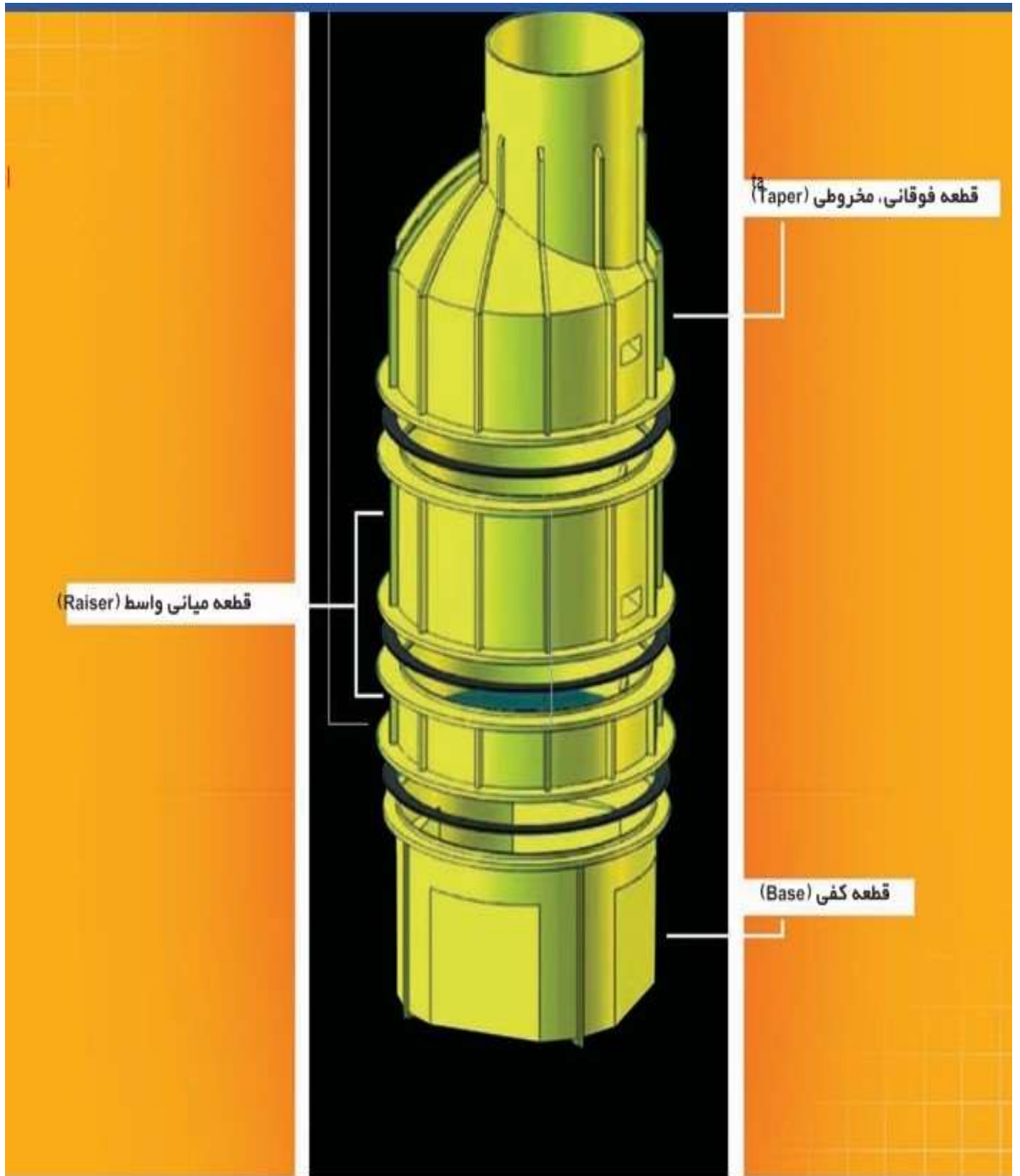

Polyethylene manhole Installation

Polyethylene watering places should be placed on a firm and prepared floor. Large pieces of rubble must be removed from the trench floor after excavation. Then the floor level is done by usage of class I soil (according to ASTM2321 standard) that is well balanced and completely mashed with (95% density) and about 30 cm thickness. According to its suitable standard, we use from a stable or pre-made concrete slab with approximately 15 cm thickness. In areas where the excavated floor (trench bottom) has loose soil or groundwater level is above the manhole base or we are encountered with saturated soil, we must use a concrete slab which is pre-made and installed at the bottom of the trench.



In areas where the soil is very loose and we are encountered with landfills, it is recommended to remove an amount of soil from the floor and replace it with suitable soil, and then the abovementioned steps are performed. These cases must be done by engineers and consultants opinions. Since the transferring of dead and live and also pressing forces are dragged down at the base of manhole, the equipments

must be considered in order to prevent soil seeping and the base where the manhole is established must be well prepared.

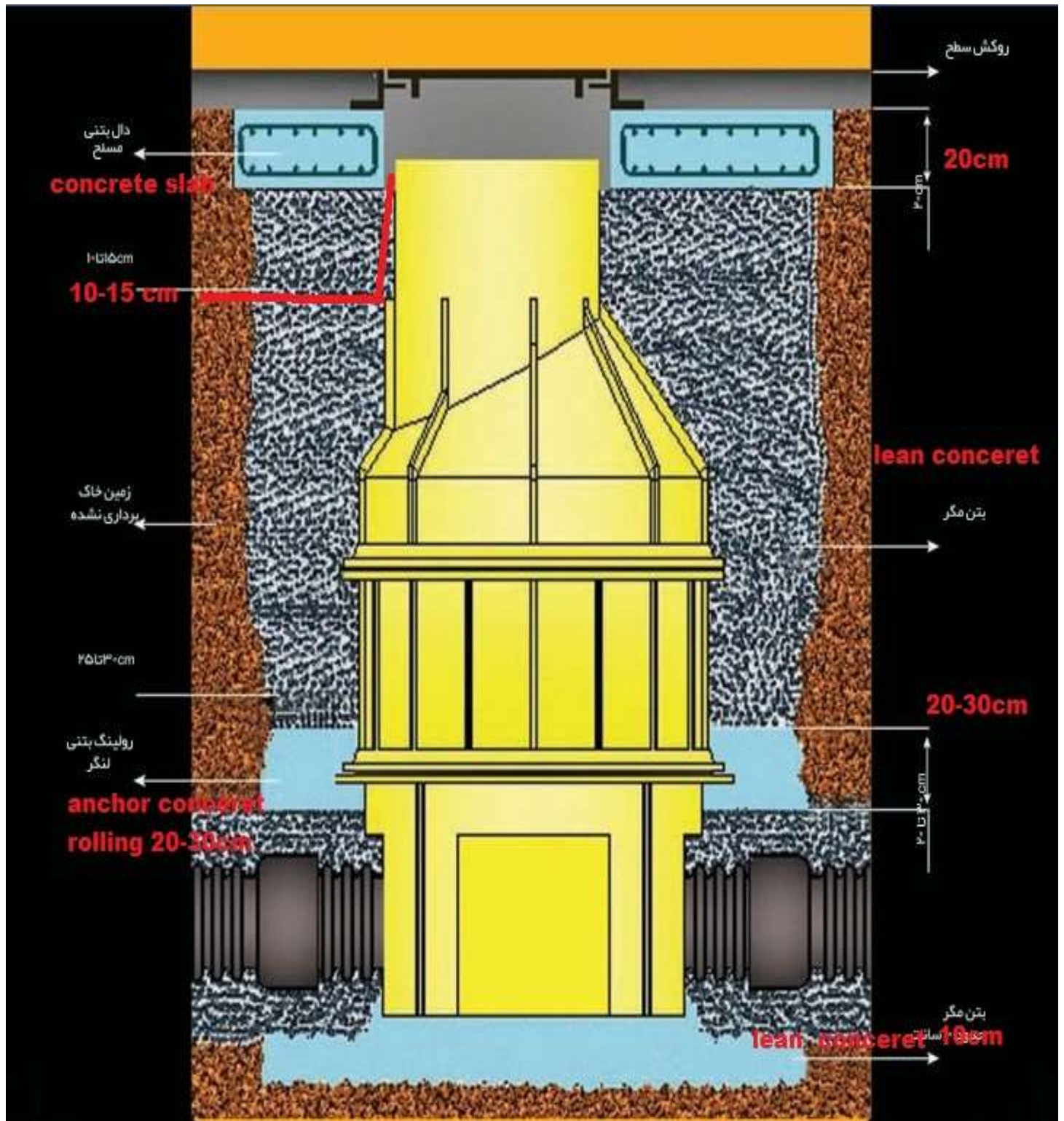

Backfill

According to ASTM1759 standard, we must have a mashed soil of class I with approximately 90% density till one-meter radius around the watering place. Therefore, in locations where these operations can be done, we must pour the backfill soil around the manhole equally (about 20 cm) in layer form and then accumulate it monotonously. We must be careful the soil is started from the wall and is continued until trench parapet and it must be balanced and layered not to make manhole deviate from balance line and it must be continued until the top and base of installation place. In areas where there is no possibility to open the trenches and the soil is intact and contains soil properties of class I with the desired density, manhole sides can be opened less (about 30-20 cm) and if there is no possibility of soil compaction, we must use substituting materials which can reach to desired density after hardening. According to the calculations which is done by the help of ANSYS software and Finite Element method by Ghadir Company and considered through frequent meetings with Water and Wastewater Organization experts, there has been gained significant results in order to replace backfills with the above-mentioned soil reached to the desired density easily and also it is able to endure different loads.

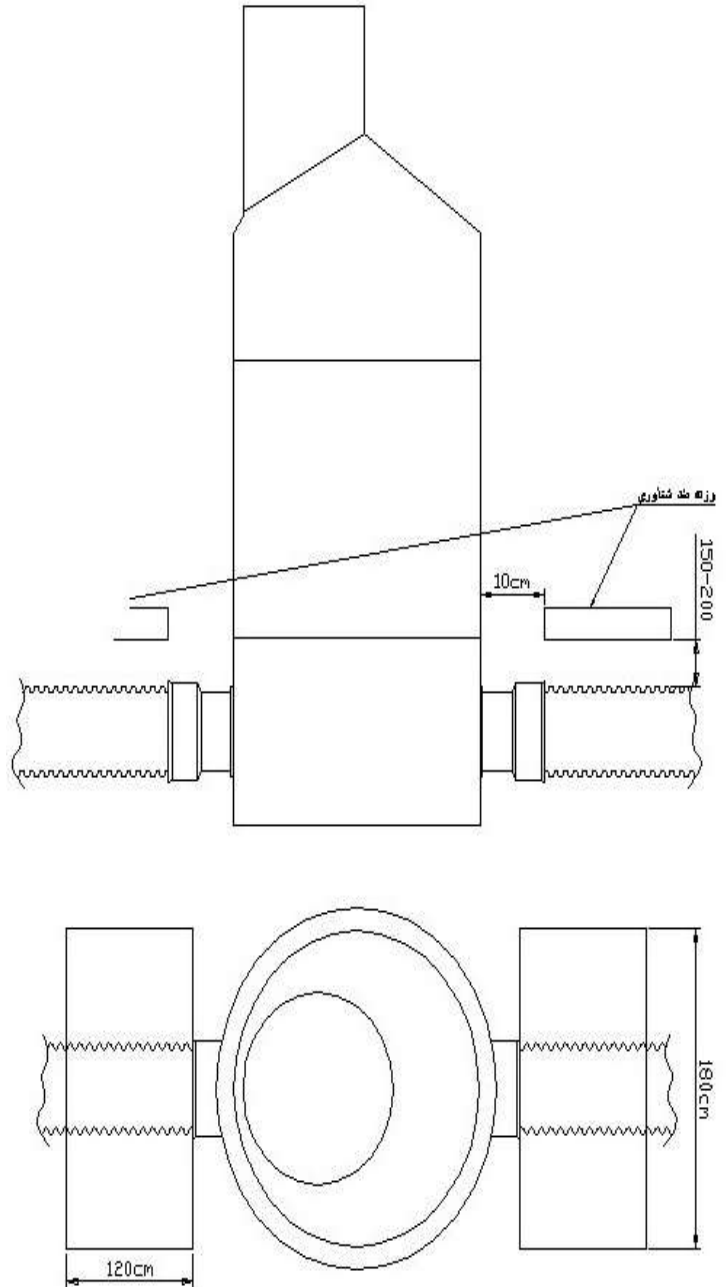

This material is the one which is presented by the America Cement Association (ACF) and it is very close to the low-substance concrete (Megr) C10 and CLSM materials.

Low-strength concrete (CLSM) is a cementitious and self-absorbed material which is used as backfill instead of mashed soil. According to CLSM ACI-116R standard, these materials have compressive strength of 8.3 MPa or less. Most of low-strength concretes have compressive strengths of 2.1 MPa or less and the basic usage of this material as backfill is in the absence of mashed soil in limited places. Since there is no need to grind surrounding soil, trench width or size can be reduced. The mixture of this low strength concrete includes water, cement, tiny and large backfill materials or both of them. Although the materials used in this mixture have the CLSM standard, it is not necessary to use standard mixtures in order to produce it. Compound materials are chosen when they are affordable and based on requiring qualities like strength, fluency and density.

Concrete slab

Depending on the amount of incoming vehicular load, its size and especially thickness is calculated. In more than 40 ton levels, the slab thickness of 25 cm and in lower, the 20 cm thickness should be considered. The slab is built in a flat shape (Reinforce Concrete) by using the 350 cement and usually in square form.

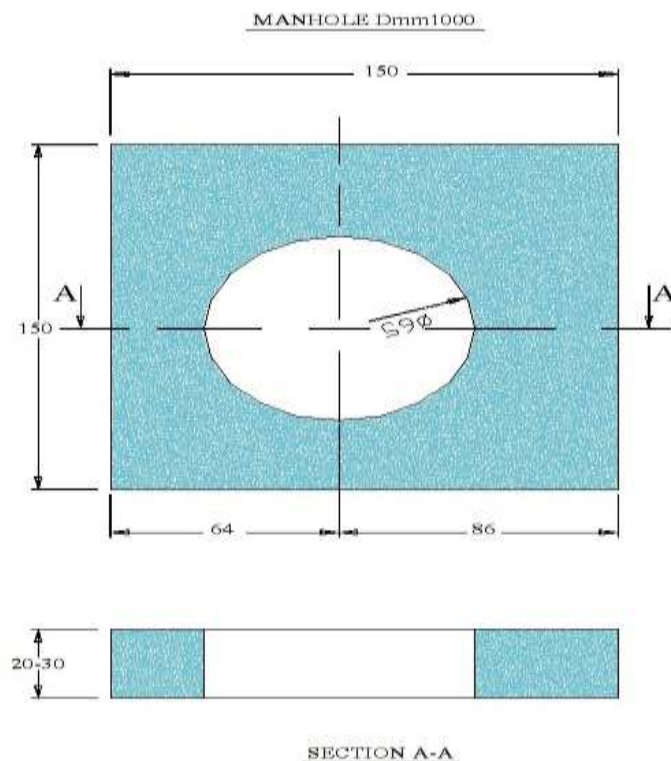

The method of single pipe parietal connection into the polyethylene manhole (manhole interior part)

As it can be seen in figure polyethylene single pipe parietal connection to polyethylene manhole must be done so that a complete seal occurs.

In order to reach standard conditions for polyethylene single pipe parietal connection into the



polyethylene manhole, the exact place of interior and exterior parts must be determined and before the installation, the interior and exterior parts must be drilled on manhole frame.

This hole is caused by means of an instrument which cuts circularly or a saw which cuts in column form on a polyethylene manhole parapet. This hole in accordance with pipe external

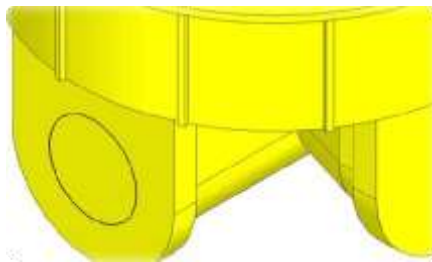

diameter beside required tolerances for installation of the sealing washer as the following formula:

- 1- Drilling diameter on manhole frame = pipe external diameter + 10 mm for the rubber washer

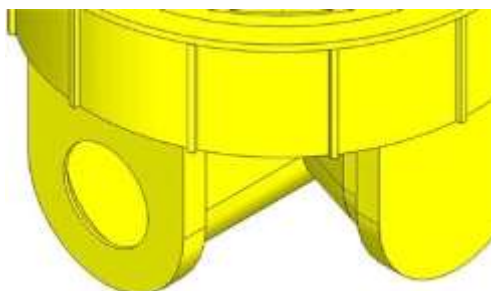

2-Then we install the sealing washer on the polyethylene manhole parapet. It is necessary to cleanse around the hole completely from filings before installing the rubber washer.

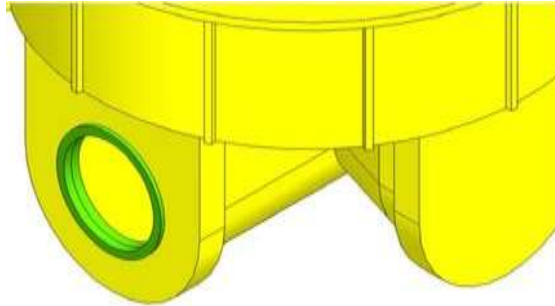

3- After completion of drilling and putting all washers for required interiors and exteriors, we should place and install polyethylene manhole according to standard instructions.

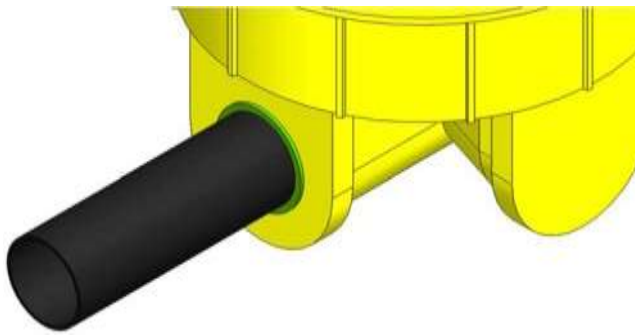

4- After fixing polyethylene manhole and installing it, the interior and exterior pipes must be installed at its place .To do this, first the washer must be lubricated with lubricants and then the pipe plunged into it with pressure

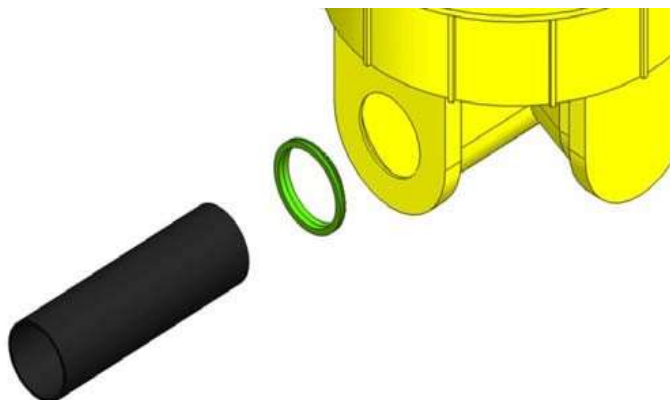

The method of single pipe parietal connection into the polyethylene manhole (manhole exterior part)

We must use replacing connection for polyethylene manholes exterior parts in sewage systems. Replacing connections are used due to the presence of coarse and fine particles and in the polyethylene manhole exterior part and the exterior parts required to be at the maximum diameter since the suspended particles do not stick on pipe and exhaust pipe and accessories in exterior part. It is necessary to consider a maximum of 400 diameters for corrugate pipe exterior hole. The installation of this system is as follow:

As it can be seen in figure 1, polyethylene single pipe parietal connection to polyethylene manhole must be done so that a complete seal occurs.

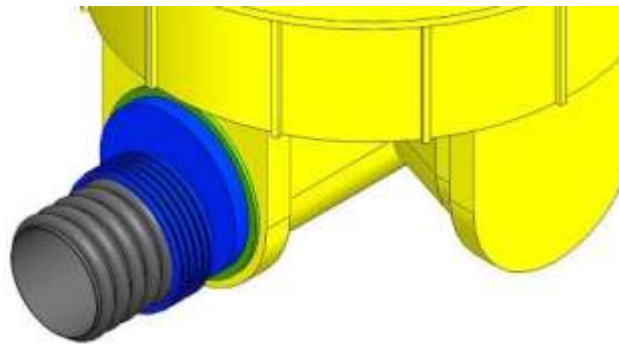

In order to reach standard conditions for polyethylene single pipe parietal connection into the polyethylene manhole, the exact place of interiors and exteriors must be determined and before the installation, the inlets and outlets must be drilled on manhole frame

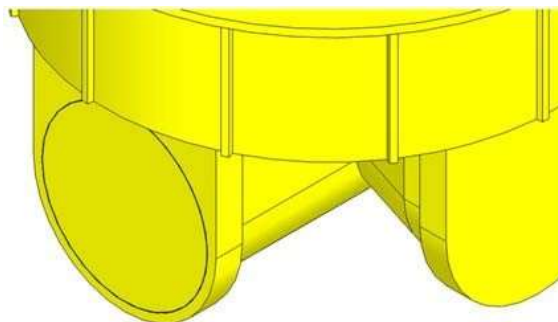

This hole is caused by means of an instrument which cuts circularly or a saw which cuts in column form on a polyethylene manhole parapet. This hole in accordance with pipe external diameter beside required tolerances for installation of the sealing washer as the following formula:

Drilling diameter on manhole frame = pipe external diameter + 10 mm for the rubber washer

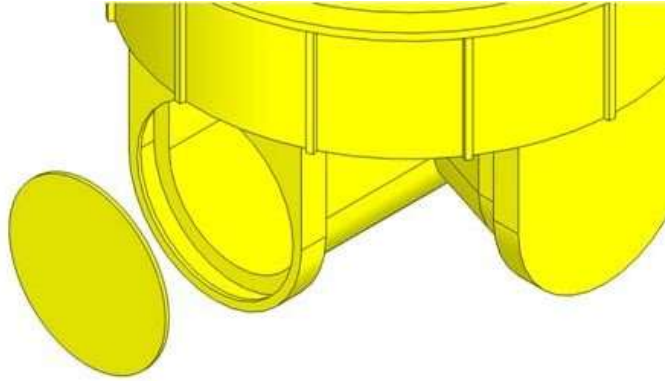

Then we install the sealing washer on the polyethylene manhole parapet. It is necessary to cleanse around the hole completely from filings before installing the rubber washer.

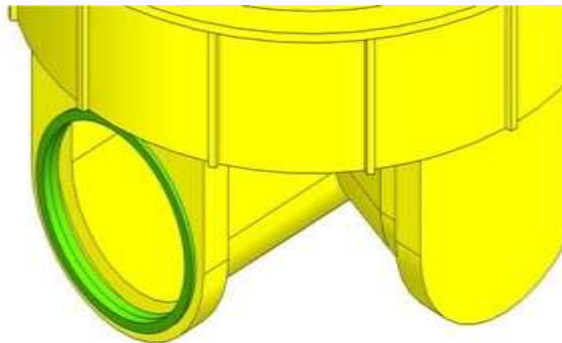

After completion of drilling and putting all washers for required interiors and exteriors, we should place and install polyethylene manhole according to standard instructions.

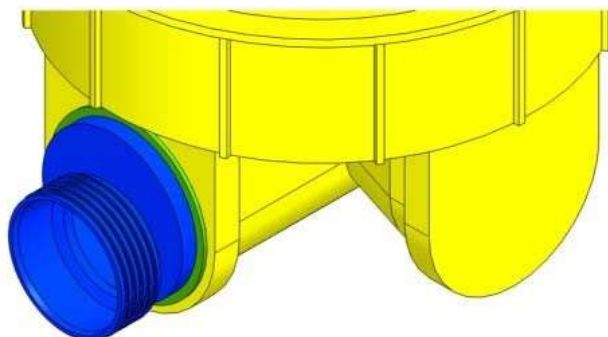

After fixing polyethylene manhole and installing it, the interior and exterior pipes must be installed at its place . To do this, first the washer must be lubricated with lubricants and then the pipe plunged into it with pressure.

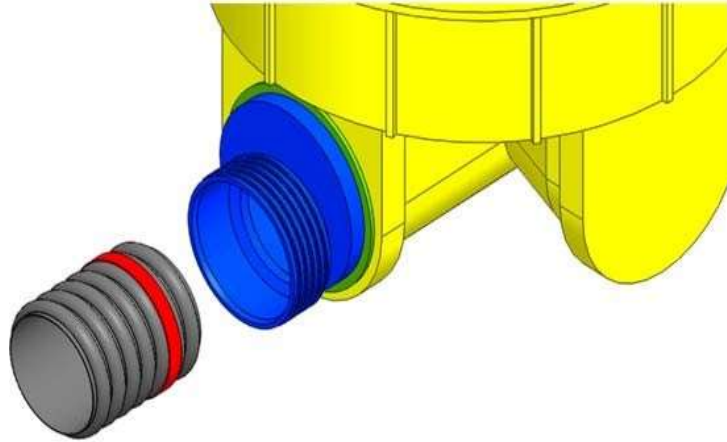

IN THE FINAL IF U FIND ANY PROBLEM PLEASE CONTACT OUR TECHNICAL MAN